



*Precision demolition, ultimate strength:*

# **CONCRETE CUTTER**

*Demolish with confidence!*

**TYMSAH**   
SERIES



## **TYMSAH<sup>®</sup>** **CONCRETE CUTTERS**

### *Why Tymsah<sup>®</sup>?*

- 500 bar test pressure on cylinders
  - Optimum Cycle Time
  - High Manganese Interchangeable Teeth
  - Four Sided Shearers
  - Stress Relieved Main Bodies
  - Anti-Shock Protected Hydromotors
  - Two Stage Rolling Elements in Slewing Bearing
  - Double Pinion
  - Infinite Rotation
  - Carbon Free Manufacturing
  - 7/24 Service
-

# Tymsah-20<sup>®</sup> Series



## TYMSAH - 20A

### Information

Class of machine	20 - 40 ton
Weight	2.160 kg
Force at position F1	105 ton
Force at position F2	135 ton
Force at position F3	190 ton
Force at position F4	560 ton

### Hydraulic

Max. operation pressure cylinder	350 bar
Oil volume cylinder	150-200 L/min
Max. operation pressure motor	170 bar
Oil volume motor	40 L/min

High Manganese Casting Teeth

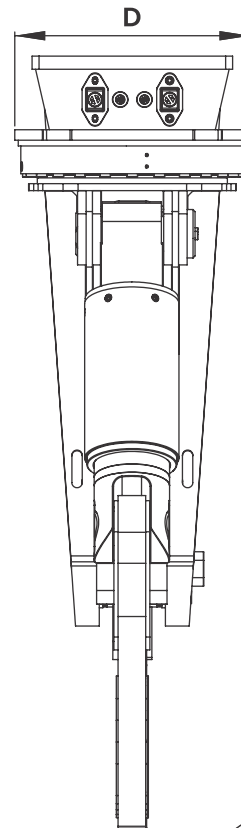
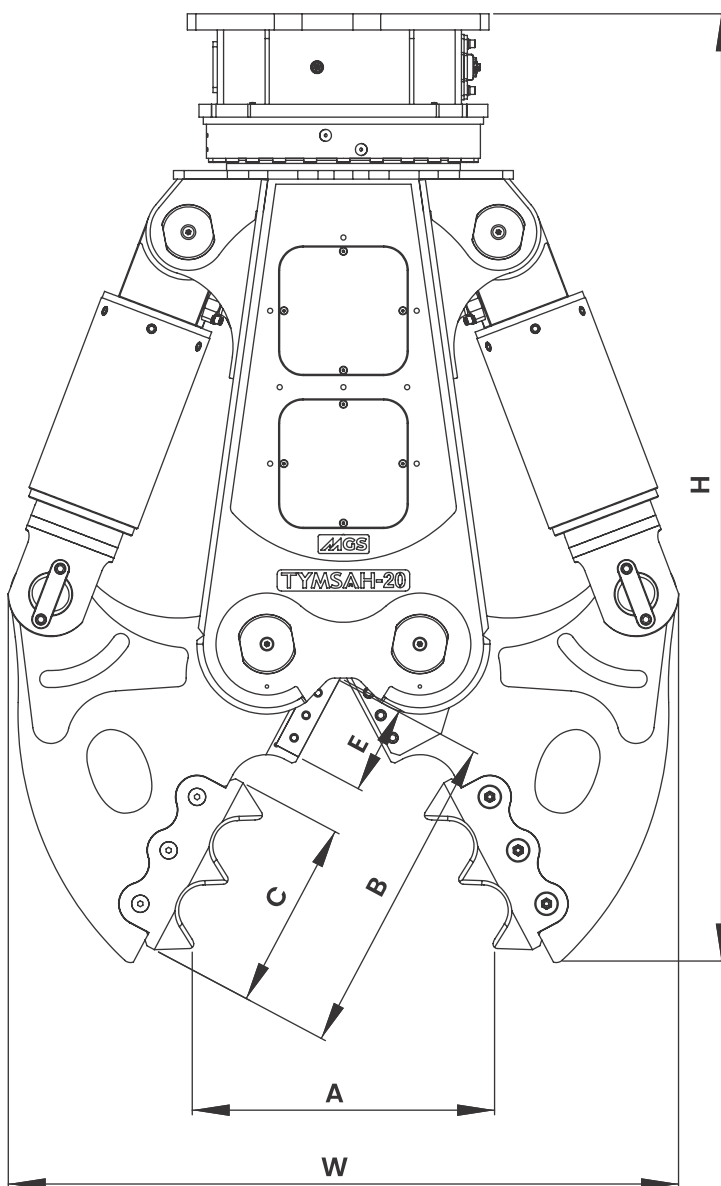

### Dimensions

A	710 mm
W	1.577 mm
B	764 mm
E	210 mm
H	2.230 mm
D	680 mm
C	445 mm

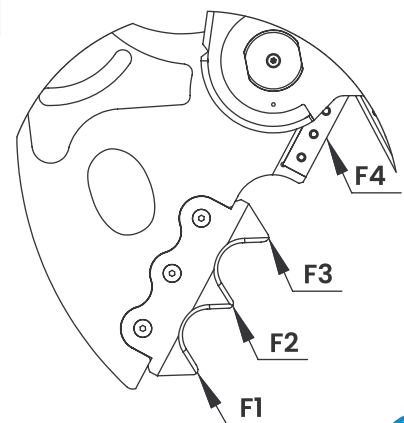



### TYMSAH - 20HA

#### Information

Class of machine	20 - 40 ton
Weight	2.150 kg
Force at position F1	105 ton
Force at position F2	135 ton
Force at position F3	190 ton
Force at position F4	560 ton

#### Hydraulic

Max. operation pressure cylinder	350 bar
Oil volume cylinder	150-200 L/min
Max. operation pressure motor	170 bar
Oil volume motor	40 L/min

HARDOX wearparts

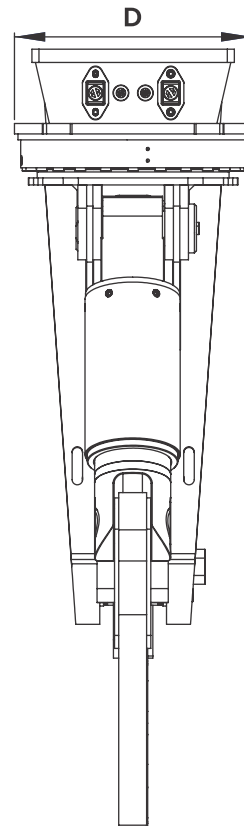
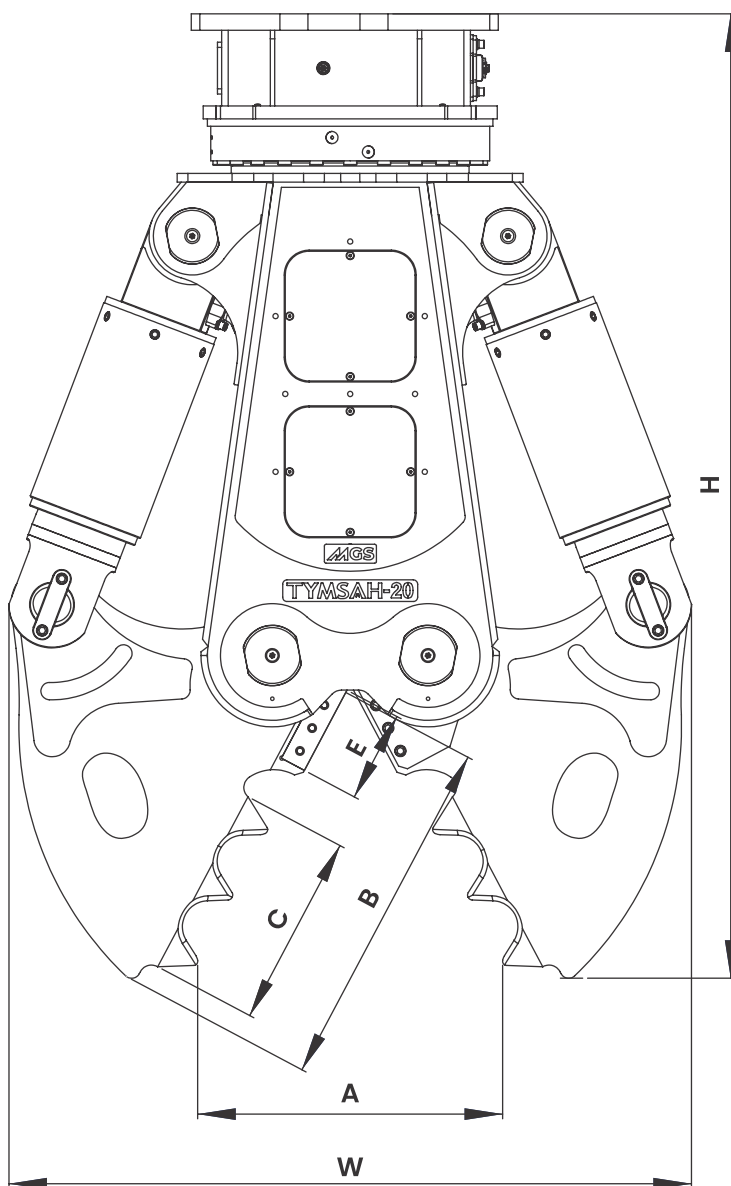

#### Dimensions

A	710 mm
W	1.577 mm
B	764 mm
E	210 mm
H	2.230 mm
D	680 mm
C	445 mm

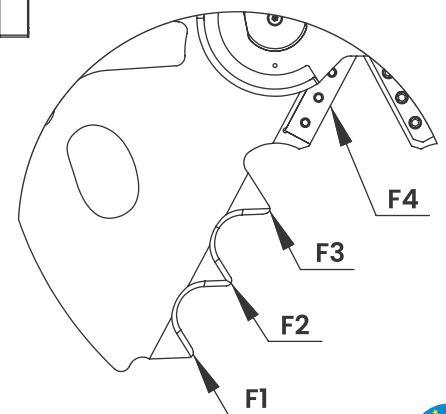



### TYMSAH - 20HB

#### Information

Class of machine	20 - 40 ton
Weight	2.150 kg
Force at position F1	94 ton
Force at position F2	143 ton
Force at position F3	560 ton

#### Hydraulic

Max. operation pressure cylinder	350 bar
Oil volume cylinder	150-200 L/min
Max. operation pressure motor	170 bar
Oil volume motor	40 L/min

HARDOX wearparts

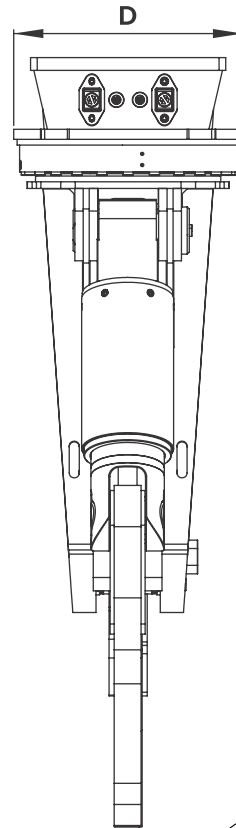
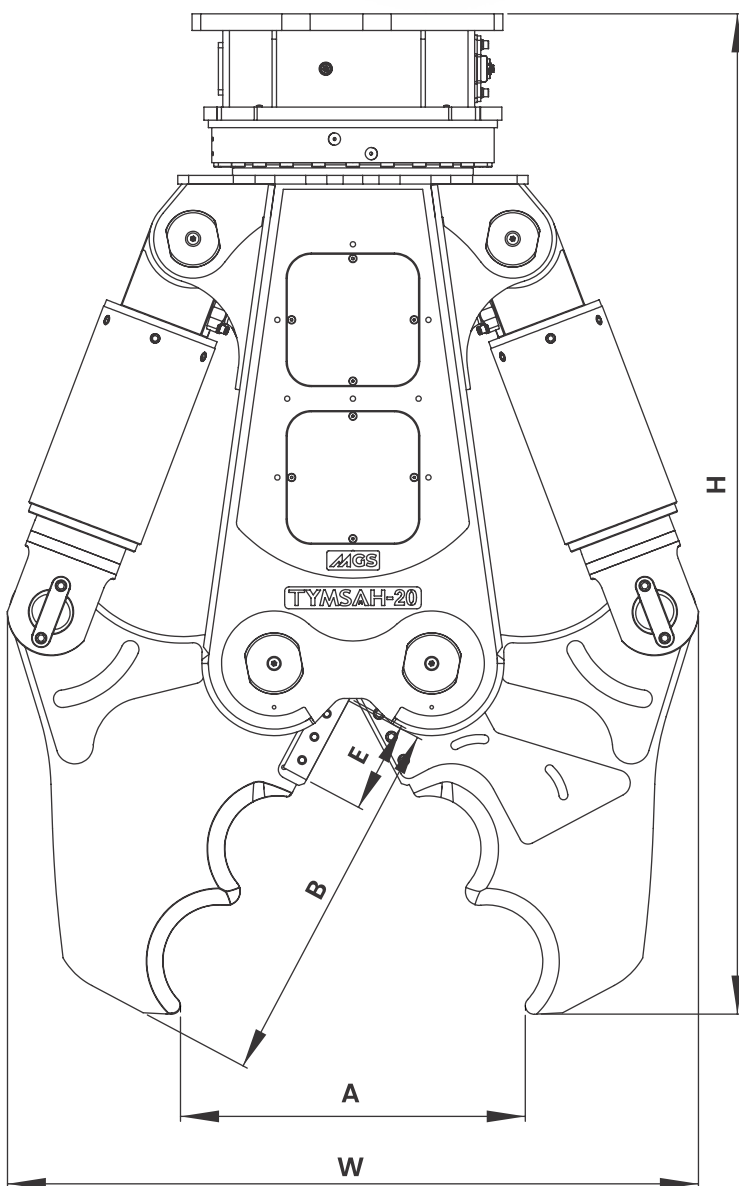

#### Dimensions

A	784 mm
W	1.577 mm
B	849 mm
E	210 mm
H	2.285 mm
D	680 mm

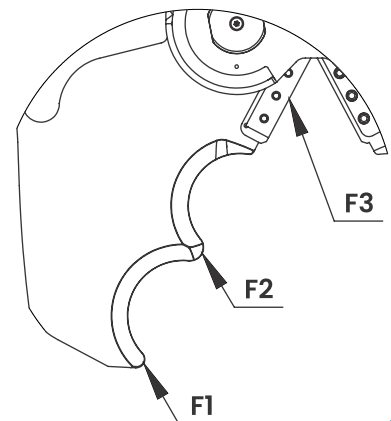



### TYMSAH - 20C

#### Information

Class of machine	20 - 40 ton
Weight	2.140 kg
Force at position F1	85 ton
Force at position F2	115 ton
Force at position F3	160 ton
Force at position F4	560 ton

#### Hydraulic

Max. operation pressure cylinder	350 bar
Oil volume cylinder	150-200 L/min
Max. operation pressure motor	170 bar
Oil volume motor	40 L/min

High Manganese Casting Teeth

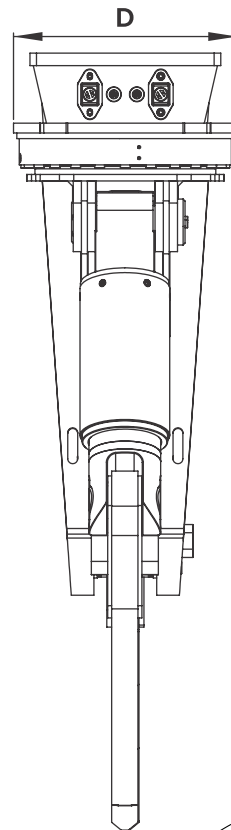
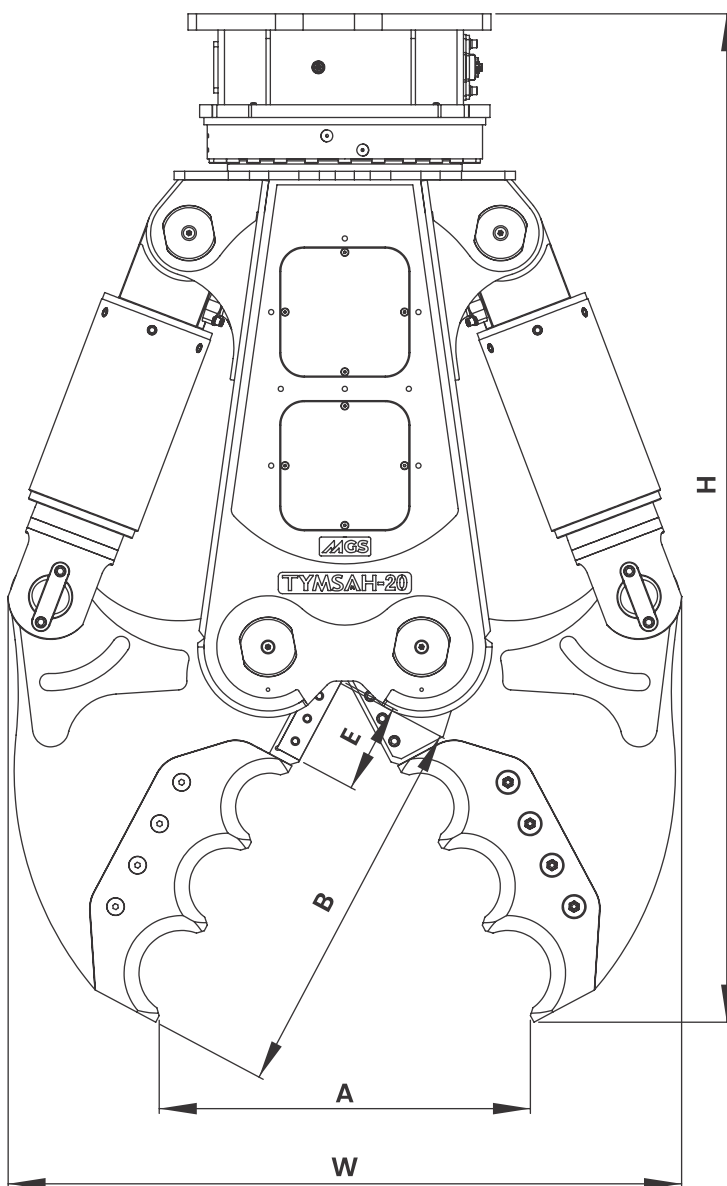

#### Dimensions

A	870 mm
W	1.577 mm
B	904 mm
E	210 mm
H	2.236 mm
D	680 mm

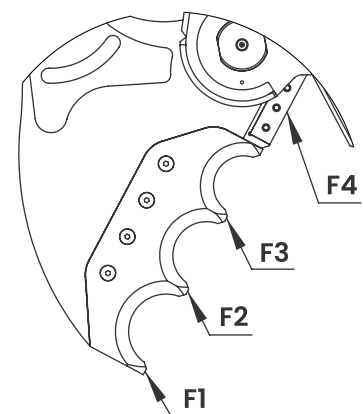

# Tymsah-30<sup>®</sup> Series



## TYMSAH - 30

### Information

Class of machine	40 - 60 ton
Weight	3.070 kg
Force at position F1	98 ton
Force at position F2	190 ton
Force at position F3	800 ton

### Hydraulic

Max. operation pressure cylinder	350 bar
Oil volume cylinder	210-250 L/min
Max. operation pressure motor	170 bar
Oil volume motor	40 L/min

High Manganese Casting Teeth

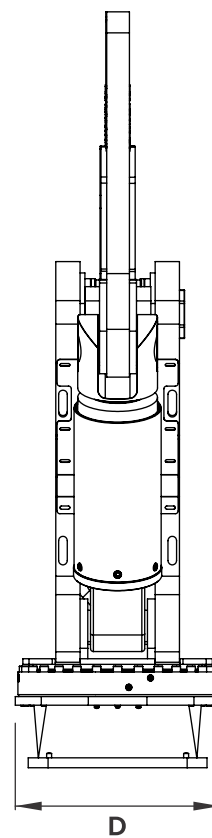
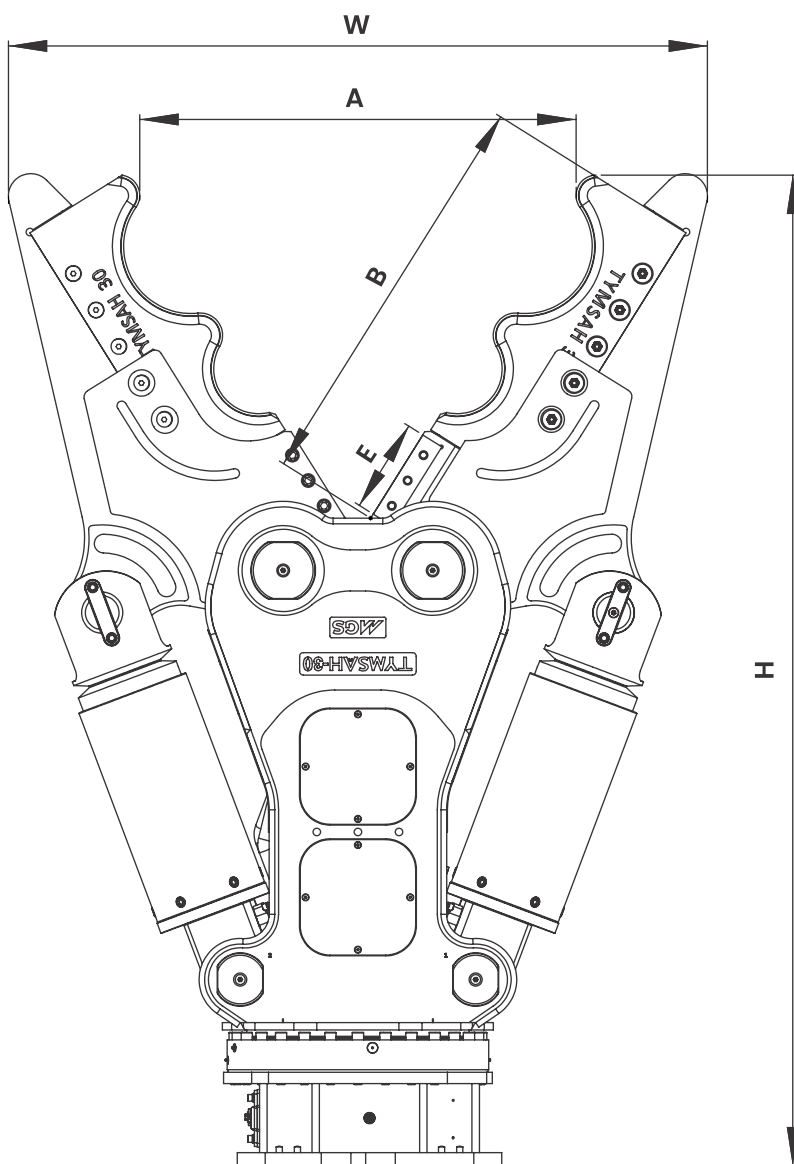

### Dimensions

A	1.167 mm
W	1.870 mm
B	1.237 mm
E	250 mm
H	2.655 mm
D	720 mm

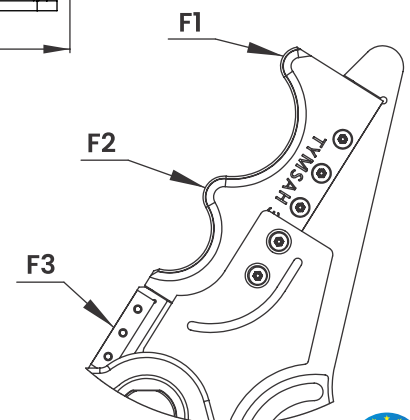

# High Reach Demolition Booms®

## High Reach Demolition Boom (Total reachable height 28 m)

### Technical Data

Boom weight	17.460 kg
Concrete cutter weight	2.400 - 3.200 kg
Adapter weight	418 kg
System working pressure	Max. 300 bar
Carrier weight	80 - 90 tons
Concrete cutter counterweight	12,4 tons
Additional counterweight	6 tons

**Strenx Performance Steel**

